



A Professional Manufacturer of Display

Manufacturer Certificated



CERT. No.: 282Q19070712006



CERT. No.: 282E19070712007

Product Specification

Model: TTX185BHT-01

18.5" TFT Display Module (1920*1080)

This module uses RoHS material

Tailor Pixels Technology Co., Ltd.

www.tailorpixels.com

tailor@tailorpixels.com

Ph: 86-755-8821 2653

文件名称	BLU Purchase Specification 模组规格书	页次	2/17
产品名称	TTX185BHT-01	版次	1.1

REVISION HISTORY

preliminary specification

Final specification

<i>Revision No.</i>	<i>Page</i>	<i>Description of changes</i>	<i>Date</i>	<i>Prepared</i>
P0		<i>Initial Release</i>	2020.11.05	

--	--	--

文件名称	BLU Purchase Specification 模组规格书	页次	3/17
产品名称	TTX185BHT-01	版次	1.1

Contents

<i>No</i>	<i>ITEM</i>	<i>Page</i>
	<i>REVISIONS HISTORY</i>	<i>2</i>
	<i>CONTENTS</i>	<i>3</i>
<i>1</i>	<i>GENERAL DESCRIPTION</i>	<i>4</i>
	<i>1.1 Introduction</i>	
	<i>1.2 Features</i>	
	<i>1.3 Applications</i>	
	<i>1.4 General Specification</i>	
<i>2</i>	<i>ABSOLUTE MAXIMUM RATINGS</i>	<i>6</i>
<i>3</i>	<i>ELECTRICAL SPECIFICATIONS</i>	<i>7</i>
	<i>3.1 TFT LCD Open Cell</i>	
<i>4</i>	<i>INTERFACE CONNECTION</i>	<i>8</i>
	<i>4.1 Open Cell Input Signal & Power</i>	
	<i>4.2 LVDS Rx Interface Timing Parameter</i>	
<i>5</i>	<i>SIGNAL TIMING SPECIFICATIONS</i>	<i>10</i>
	<i>5.1 Timing Parameters (DE only mode)</i>	
	<i>5.2 Signal Timing Waveform</i>	
	<i>5.3 Power Sequence</i>	
<i>6</i>	<i>OPTICAL SPECIFICATIONS</i>	<i>14</i>
<i>7</i>	<i>2D Drawing</i>	<i>15</i>

--	--	--

文件名称	BLU Purchase Specification 模组规格书	页次	4/17
产品名称	HBM185FH10A	版次	1.1

1.0 GENERAL DESCRIPTION

1.1 Introduction

TTX185BHT-01 is a color active matrix TFT LCD MDL using amorphous silicon TFT's (Thin Film Transistors) as an active switching devices. This Open Cell has a 18.5 inch diagonally measured active area with FHD resolutions (1920 horizontal by 1080 vertical pixel array). Each pixel is divided into RED, GREEN, BLUE dots which are arranged in vertical stripe and this module can display 16.7M colors. The TFT-LCD panel is adapted for a low reflection and higher color type.

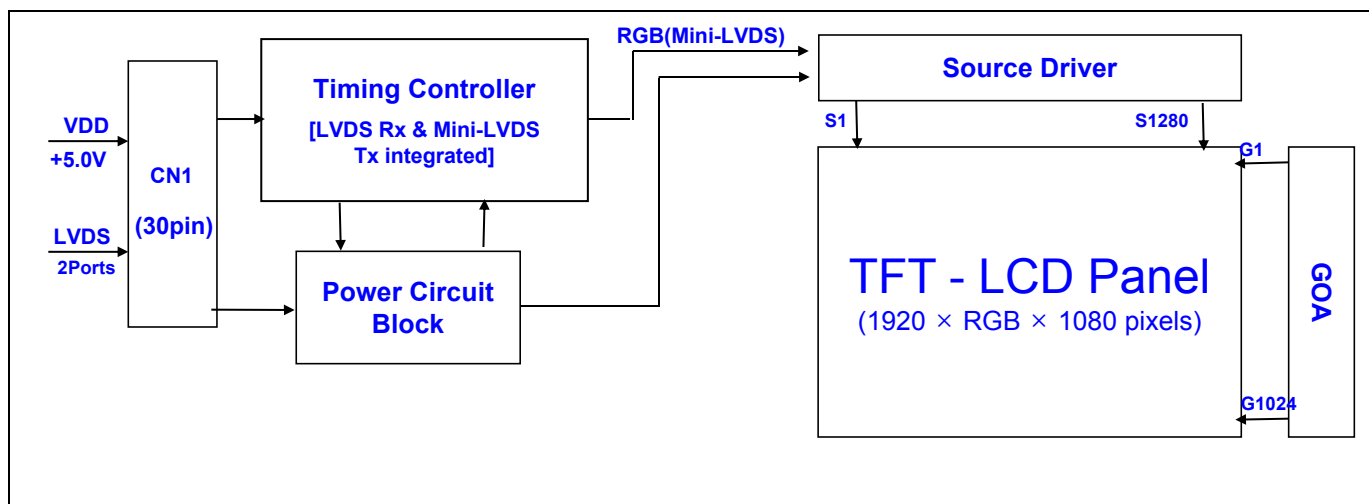

1.2 Features

- LVDS interface with 2 pixel / clock
 - High-speed response
 - Low color shift image quality
 - 8-bit color depth, display 16.7M colors
- Wide viewing angle
 DE (Data Enable) only mode
 HADS technology is applied for high display quality
 RoHS compliant

文件名称	BLU Purchase Specification 模组规格书	页次	5/17
产品名称	TTX185BHT-01	版次	1.1

1.3 Application

- Commercial Digital Display
- Display Terminals for Control System
- Landscape and Portrait Display

1.4 General Specification

< Table 1. General Specifications >

Parameter	Specification	Unit	Remarks
Active area	408.96 (H) × 230.04 (V)	mm	
Number of pixels	1920(H) × 1080(V)	pixels	
Pixel pitch	213(H) × 213(V)	um	
Pixel arrangement	Pixels RGB Vertical stripe		
Display colors	16.7M	colors	Real 8bits
Display mode	Normally Black		
Dimensional outline	430.4(H) × 254.6(V) × 0.8(D)	mm	Detail refer to drawing
Weight	TBD	g	
Sealing Area	6.69/5/6.62/6.62	mm	U/D/L/R
Surface Treatment	Haze 25%		

文件名称	BLU Purchase Specification 模组规格书	页次	6/17
产品名称	TTX185BHT-01	版次	1.1

2.0 ABSOLUTE MAXIMUM RATINGS

The followings are maximum values which, if exceed, may cause faulty operation or damage to the unit. The operational and non-operational maximum voltage and current values are listed in Table 2.

< Table 2. Open Cell Electrical Specifications >

[VSS=GND=0V]

Parameter	Symbol	Min.	Max.	Unit	Remark
Power Supply Voltage	VDD	-0.3	6.0	V	Ta = 25 °C
Logic Supply Voltage	VIN	VSS-0.3	VDD+0.3	V	
Operating Temperature	T _{OP}	0	+50	°C	Note 1
Storage Temperature	T _{SUR}	-20	+60	°C	
	T _{ST}	-20	+60	°C	
Operating Ambient Humidity	Hop	10	80	%RH	
Storage Humidity	Hst	10	80	%RH	

文件名称	BLU Purchase Specification 模组规格书	页次	7/17
产品名称	TTX185BHT-01	版次	1.1

3.0 ELECTRICAL SPECIFICATIONS

3.1 TFT LCD Open Cell

< Table 3. Open Cell Electrical Specifications >

[Ta =25 ± 2 °C]

Parameter		Symbol	Values			Unit	Remark
			Min	Typ	Max		
Power Supply Input Voltage		VDD	4.5	5.0	5.5	Vdc	
Power Supply Ripple Voltage		VRP	-	-	200	mV	
Power Supply Current		IDD	-	400	1000	mA	Note 1
Power Consumption		PDD	-	2	5	Watt	
Rush current		IRUSH	-		3.0	A	Note 2
LVDS Interface	Differential Input High Threshold Voltage	VLVTH	+100	-	+300	mV	
	Differential Input Low Threshold Voltage	VLVTL	-300	-	-100	mV	
	Input Differential Voltage	VID	200	-	600	mV	
	Differential input common mode voltage	VCM	1.0	1.2	1.5	V	

Note 1 : The supply voltage is measured and specified at the interface connector of LCM.

The current draw and power consumption specified is for VDD=5.0V,

Frame rate $f_v=60\text{Hz}$ and Clock frequency = 74.25MHz.

Test Pattern of power supply current

a) Typ : Mosaic 7X5 (L0/L255)

b) Max : Skip 1 dot Pattern

c) Flicker Pattern

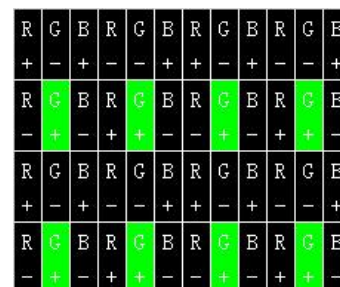
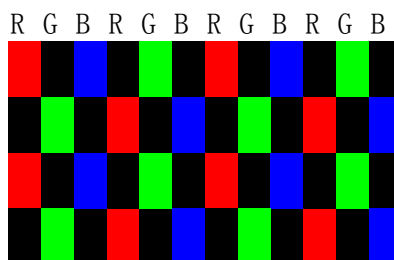
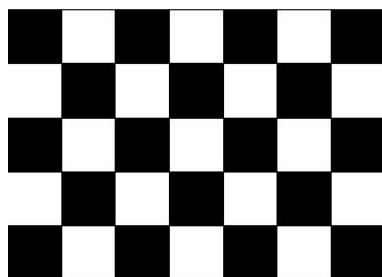

Note 2 : The duration of rush current is about 2ms and rising time of Power Input is 1ms(min)

文件名称	BLU Purchase Specification 模组规格书	页次	8/17
产品名称	TTX185BHT-01	版次	1.1

4.0 INTERFACE CONNECTION

4.1 Open Cell Input Signal & Power (CN101)

- LVDS Connector : IS100-L300-C23(UJU), MSBKT2407P30HC(STM) or Equivalent.

< Table 4. Open Cell Input Connector Pin Configuration >

Pin No	Symbol	Description	Pin No	Symbol	Description
1	RX00-	Negative Transmission data of Pixel 0 (ODD)	16	RXE1+	Positive Transmission data of Pixel 1 (EVEN)
2	RX00+	Positive Transmission data of Pixel 0 (ODD)	17	GNG	Power Ground
3	RX01-	Negative Transmission data of Pixel 1 (ODD)	18	RXE2-	Negative Transmission data of Pixel 2 (EVEN)
4	RX01+	Positive Transmission data of Pixel 1 (ODD)	19	RXE2+	Positive Transmission data of Pixel 2 (EVEN)
5	RX02-	Negative Transmission data of Pixel 2 (ODD)	20	RXEC-	Negative Transmission Clock (EVEN)
6	RX02+	Positive Transmission data of Pixel 2 (ODD)	21	RXEC+	Positive Transmission Clock (EVEN)
7	GND	Power Ground	22	RXE3-	Negative Transmission data of Pixel 3 (EVEN)
8	RXOC-	Negative Transmission Clock (ODD)	23	RXE3+	Positive Transmission data of Pixel 3 (EVEN)
9	RXOC+	Positive Transmission Clock (ODD)	24	GND	Power Ground
10	RX03-	Negative Transmission data of Pixel 3 (ODD)	25	NC	No. Connection
11	RX03+	Positive Transmission data of Pixel 3 (ODD)	26	NC	No. Connection
12	RXE0-	Negative Transmission data of Pixel 0 (EVEN)	27	NC	No. Connection
13	RXE0+	Positive Transmission data of Pixel 0 (EVEN)	28	VDD	Power Supply: +5V
14	GND	Power Ground	29	VDD	
15	RXE1-	Negative Transmission data of Pixel 1 (EVEN)	30	VDD	

Note : Pin 24 should be connected with GND.

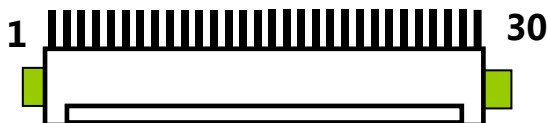

文件名称	BLU Purchase Specification 模组规格书	页次	9/17
产品名称	TTX185BHT-01	版次	1.1

4.2 LVDS Rx Interface Timing Parameter

The specification of the LVDS Rx interface timing parameter is shown in Table 6.

<Table 6. LVDS Rx Interface Timing Specification>

Item	Symbol	Min	Typ	Max	Unit	Remark
CLKIN Period	tRCP	14.8	18.5	22.2	nsec	
Receiver Data Input Margin	tRMG	-0.35	-	0.35	nsec	fCLKIN=110MHz
		-0.40	-	0.40	nsec	fCLKIN=95MHz
		-0.45	-	0.45	nsec	fCLKIN=85MHz
		-0.60	-	0.60	nsec	fCLKIN=65MHz
Input Data 0	tRIP1	- tRMG	0.0	tRMG	Clock	
Input Data 1	tRIP0	T/7- tRMG	T/7	T/7+ tRMG	Clock	
Input Data 2	tRIP6	2 T/7- tRMG	2T/7	2T/7+ tRMG	Clock	
Input Data 3	tRIP5	3T/7- tRMG	3T/7	3T/7+ tRMG	Clock	
Input Data 4	tRIP4	4T/7- tRMG	4T/7	4T/7+ tRMG	Clock	
Input Data 5	tRIP3	5T/7- tRMG	5T/7	5T/7+ tRMG	Clock	
Input Data 6	tRIP2	6T/7- tRMG	6T/7	6T/7+ tRMG	Clock	

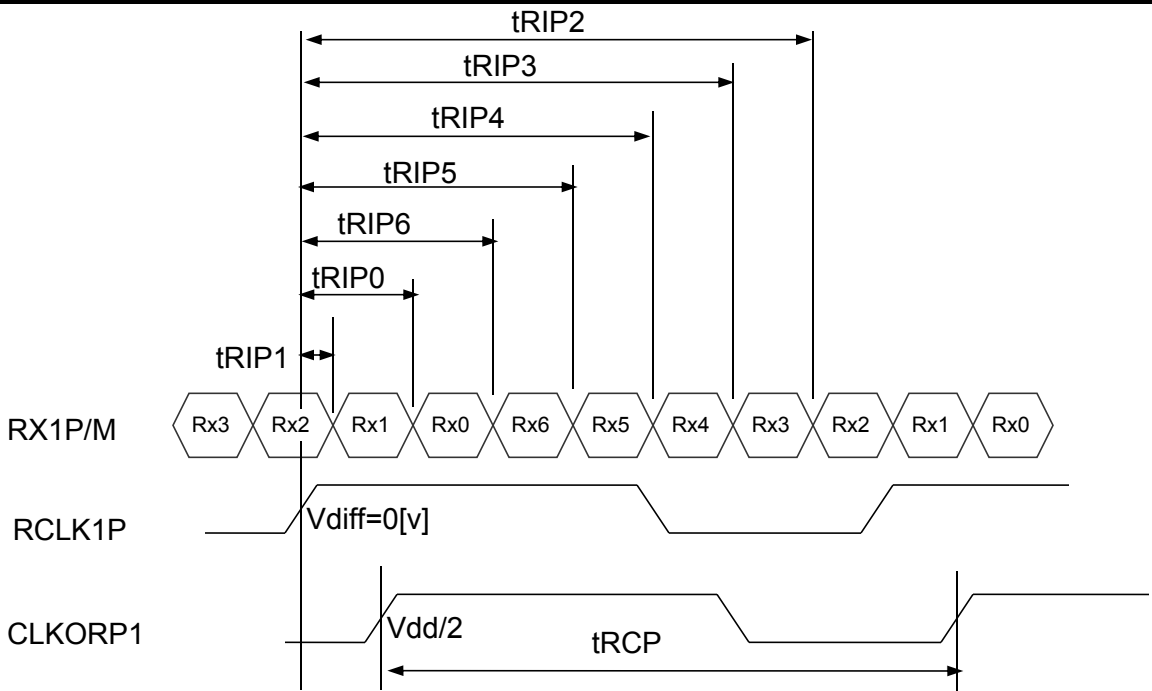

* Vdiff = (RXz+)-(RXz-),..., (RXCLK+)-(RXCLK-)

文件名称	BLU Purchase Specification 模组规格书	页次	10/17
产品名称	TTX185BHT-01	版次	1.1

5.0 SIGNAL TIMING SPECIFICATION

5.1 Timing Parameters (DE only mode)

< Table 8. Timing Table >

Item		Symbols	Min	Typ	Max	Unit	
Clock	Frequency	1/Tc	60	74.25	78	MHz	
	High Time	Tch	-	4/7Tc	-		
	Low Time	Tcl	-	3/7Tc	-		
Frame Period		Tv	1100	1125	1149	lines	
			48.5	60	63	Hz	
Horizontal Active Display Term		Valid	t _{HV}	-	960	-	t _{CLK}
		Total	t _{HP}	1060	1100	1200	t _{CLK}
Vertical Active Display Term		Valid	t _{VV}	-	1080	-	t _{HP}
		Total	t _{VP}	1100	1125	1149	t _{HP}

Notes: This product is DE only mode. The input of Hsync & Vsync signal does not have an effect on normal operation.

< Table 9. LVDS Input SSCG>

Symbol	Parameter	Condition	Min	Typ	Max	Unit
F	LVDS Input frequency	-	60	74.25	78	MHz
T _{LVSK}	LVDS channel to channel skew	F=100MHz V _{IC} =1.2V V _{ID} =±400mV	-380	-	+380	ps
F _{LVMOD}	Modulating frequency of input clock during SSC		60	-	85	KHz
F _{LVDEV}	Maximum deviation of input clock frequency during SSC		-3	-	+3	%
T _{CY-CY}	Cycle to Cycle jitter		-	-	100	ps

文件名称	BLU Purchase Specification 模组规格书	页次	11/17
产品名称	TTX185BHT-01	版次	1.1

5.2 Signal Timing Waveform

5.2.1 Sync Timing Waveforms

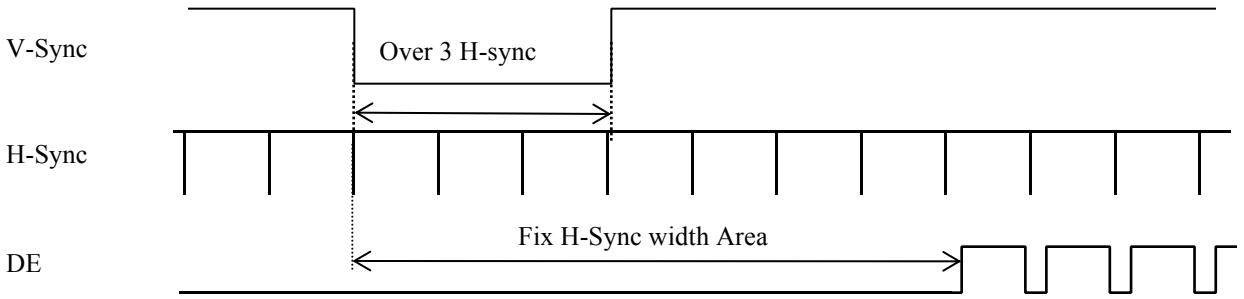

- 1) Need over 3 H-sync during V-Sync Low
- 2) Fix H-Sync width from V-Sync falling edge to first rising edge

5.2.2 Vertical Timing Waveforms

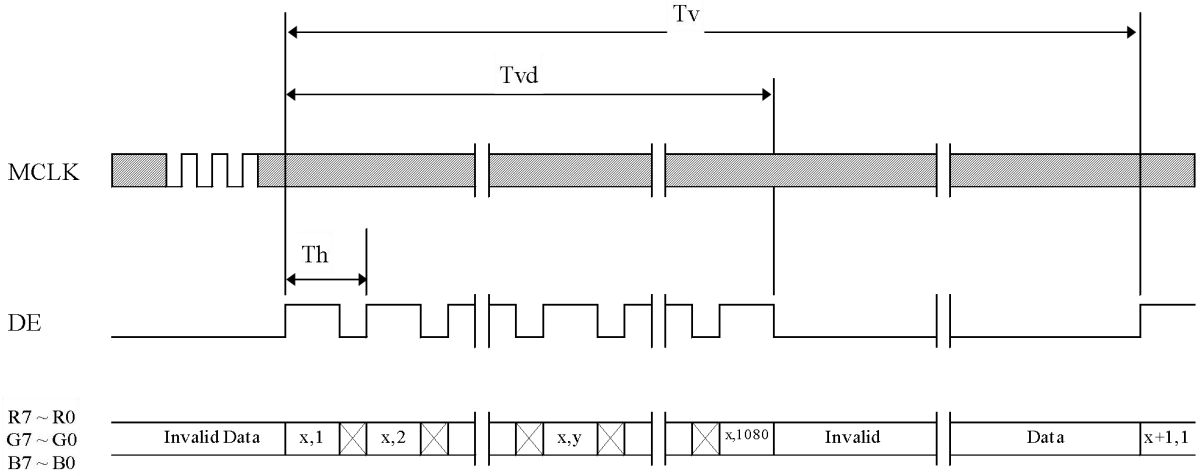

文件名称	BLU Purchase Specification 模组规格书	页次	12/17
产品名称	TTX185BHT-01	版次	1.1

5.2.3 Horizontal Timing Waveforms

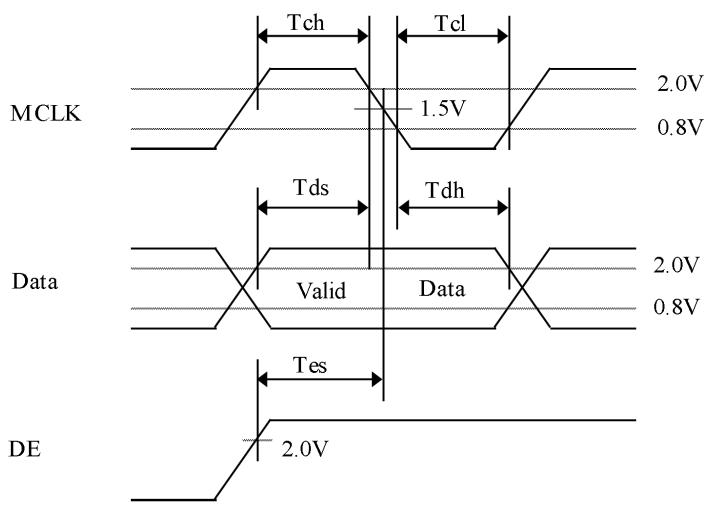
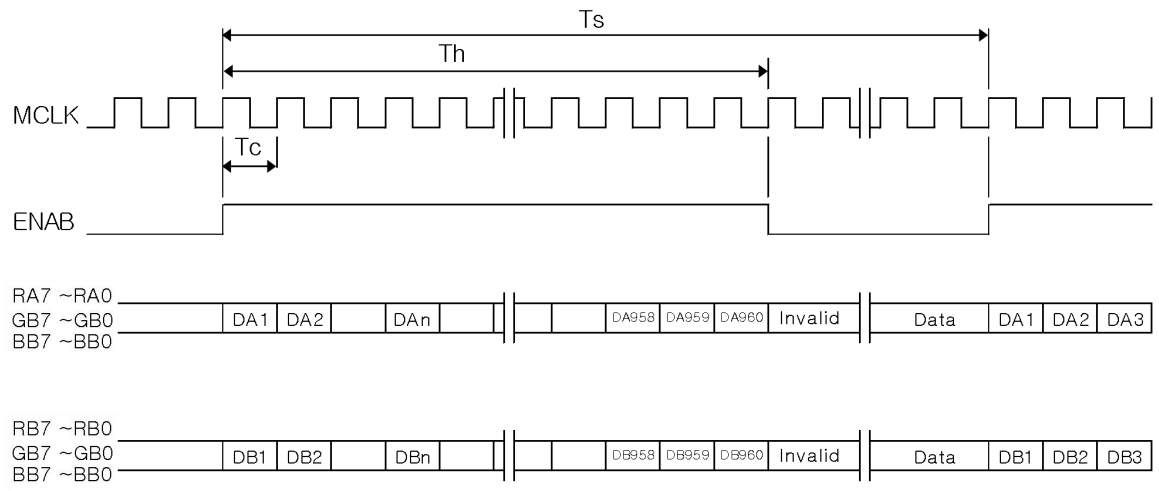

文件名称	BLU Purchase Specification 模组规格书	页次	13/17
产品名称	TTX185BHT-01	版次	1.1

5.3 Power Sequence

To prevent a latch-up or DC operation of the Open Cell, the power on/off sequence shall be as shown in below

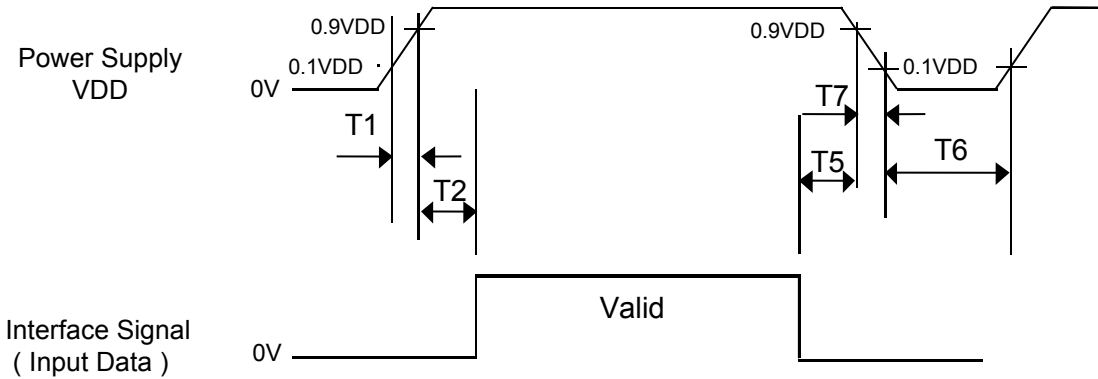

< Table 11. Sequence Table >

Parameter	Values			Units
	Min	Typ	Max	
T1	0.5	-	20	ms
T2	10	-	100	ms
T3	200	-	-	ms
T4	200	-	-	ms
T5	0	-	-	ms
T6	1	-	-	s

- Notes:
1. Back Light must be turn on after power for logic and interface signal are valid.
 2. Even though T1 is out of SPEC, it is still ok if the inrush current of VDD is below the limit.
 3. When $VDD < 0.9VDD$ (Typ.), Power off.
 4. T7 decreases smoothly, if there were rebounding voltage, it must smaller than 5 volts.

文件名称	BLU Purchase Specification 模组规格书	页次	14/17
产品名称	TTX185BHT-01	版次	1.1

6.0 OPTICAL SPECIFICATIONS

The test of optical specifications shall be measured in a dark room (ambient luminance 1 lux and temperature=25 ±2°C) with the equipment of Luminance meter system (Goniometer system and PR730) and test unit shall be located at an approximate distance 180cm from the LCD surface at a viewing angle of θ and Φ equal to 0°. We refer to $\theta_{\Phi=0}$ ($=\theta_3$) as the 3 o'clock direction (the "right"), $\theta_{\Phi=90}$ ($=\theta_{12}$) as the 12 o'clock direction ("upward"), $\theta_{\Phi=180}$ ($=\theta_9$) as the 9 o'clock direction ("left") and $\theta_{\Phi=270}$ ($=\theta_6$) as the 6 o'clock direction ("bottom"). While scanning θ and/or Φ , the center of the measuring spot on the Display surface shall stay fixed. The measurement shall be executed after 30 minutes warm-up period. VDD shall be 12.0V at 25°C. Optimum viewing angle direction is 6 o'clock.

< Table 12. Optical Table >

[VDD = 12.0V, Frame rate = 60Hz, Ta =25±2 °C]

Parameter		Symbol	Condition	Min	Typ	Max	Unit	Remark
Viewing Angle	Horizontal	θ_3	CR > 10	80	89	-	Deg.	Note 1
		θ_9		80	89	-	Deg.	
	Vertical	θ_{12}		80	89	-	Deg.	
		θ_6		80	89	-	Deg.	
Brightness		Lv	$\theta = 0$ (Center) Normal Viewing Angle	350	400	-	nit	
Contrast ratio		CR		700:1	1000:1	-		Note 2
White luminance uniformity		ΔY		75	80	-	%	Note 3
Reproduction of color	White	W_x		TYP. - 0.03	TYP. + 0.03	TBD	Note 4	
		W_y				TBD		
	Red	R_x				TBD		
		R_y				TBD		
	Green	G_x	TBD					
		G_y	TBD					
	Blue	B_x	TBD					
		B_y	TBD					
Color Gamut			68	72	-	%		
Cell Transmittance			TBD	TBD				
Response Time	G to G	T_g	-	14	20	ms	Note 5	

文件名称	BLU Purchase Specification 模组规格书	页次	15/17
产品名称	TTX185BHT-01	版次	1.1

2. . BACKLIGHT UNIT

Parameter	Symbol	Value			Unit	Note
		Min.	Typ.	Max.		
LED Light Bar Input Voltage Per Input Pin	VPIN	36	39.2	43	V	(1), Duty=100%, IPIN=(60mA)
灯条总电流 I	IPIN	---	320	360	mA	(1), (2) Duty=100%
LED Life Time	LLED	30000			Hrs	(3)
Power Consumption	PBL	12.6	---	---	W	(1) Duty=100%, IPIN=(60mA)

灯条串并定义及接口型号定义：4014灯珠(90MA) 13串4并

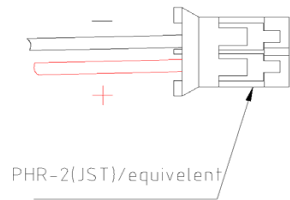

环境温度(Ta)=25°C±2 湿度 HR=65%±10

項目 Item	單位 unit	規格 Sption			备注 Remark		
		MIN	TYP	MAX			
1	模组亮度 BLU Brightness	Center point	cd/m ²	350	400	---	Center point (NOTE 1)
	均匀性 Uniformity	9点	%	72	75	---	(NOTE2)
2	模组色度 LCM CIE	x	---	-0.030	0.313	+0.030	Center point
		y	---	-0.030	0.329	+0.030	Center point

